

Acrylic Lightbox

25 x 25 Angle Trim

COMPONENT

Saled Australia's aluminium extrusions have been developed in collaboration with the experienced and outstanding Australian aluminium company, Capral, utilizing local die-making expertise. In a commitment to sustainability, the aluminium extrusions are crafted from low-carbon aluminium, forming part of a solution to protect our collective future. The main extrusion bar arrangement has been modified to accommodate a more robust support section, allowing for the rapid assembly of the acrylic lightbox frame. This modification enhances the fabrication of the remarkable acrylic box system.

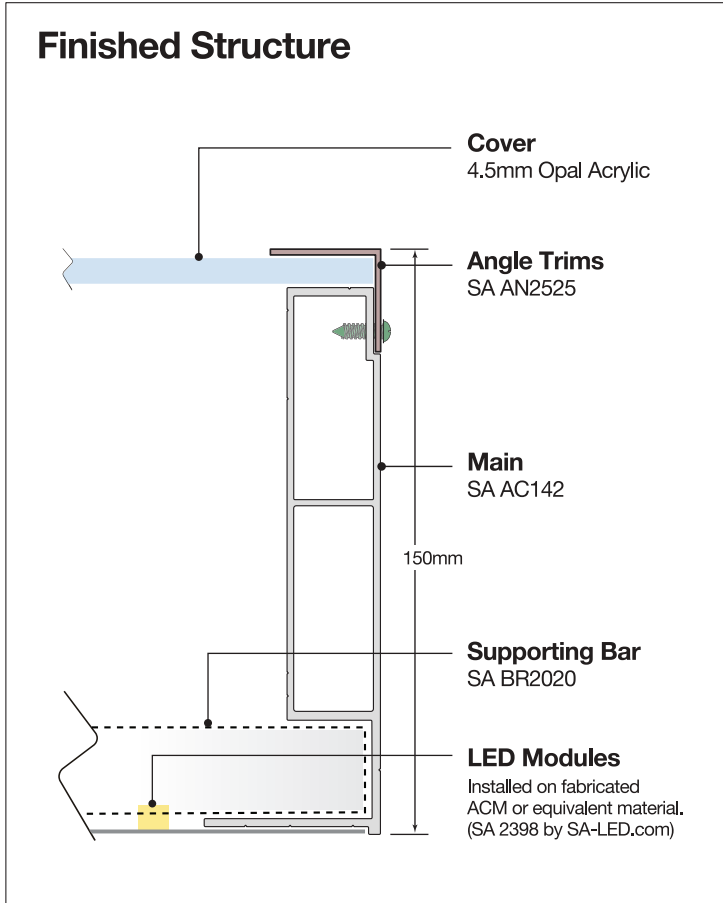

Component List

No.	Type	Item Code	Description
1	Main	SA AC142	142mm Extrusion
2	Angle Trim	SA AN2525	25 x 25 x 1.6mm
3	SHS Bar	SA BR2020	20 x 20 x 3mm

Main Extrusion SA AC142

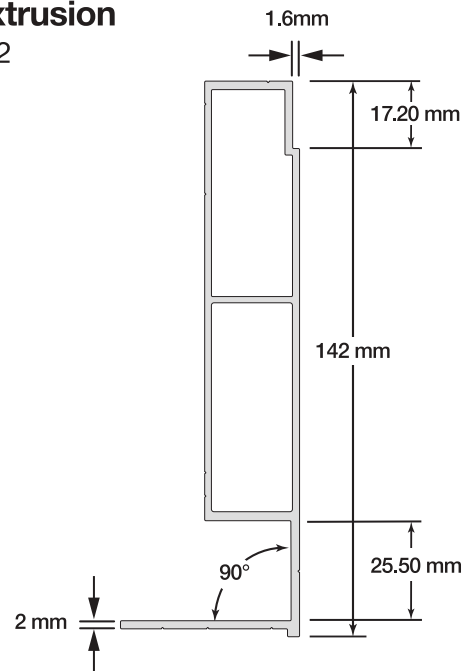

*Please note that Acrylic sheets are not supplied.

Angle Trim SA AN2525

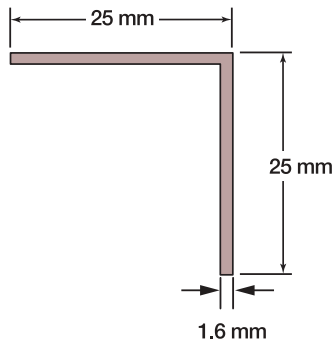

SHS Bar (Optional) SA BR2020

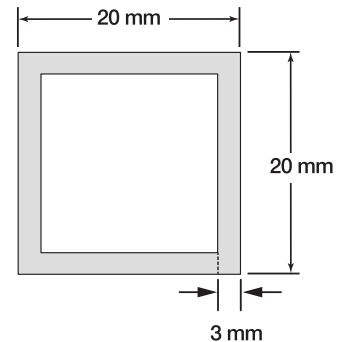

ALL AVAILABLE IN www.sa-led.com

SA-LED
AUSTRALIA

© Copyright SAled Australia Pty Ltd 2024. All rights reserved.

Sale & Enquiry

TEL +61 7 3219 6711 | 0402 136 631
E-Mail service@sa-led.com

Head Office & Warehouse

40 Wright Place Algester QLD 4115
Mon - Fri 7:30am to 3:30pm